

VIRGINIA DEPARTMENT OF PUBLIC UTILITIES
POLICY

Subject: REQUEST FOR UTILITY SERVICE			Index: CUSTOMER SERVICE	
			Number: 100.01	
Effective Date: 11/01/2017	Supersedes: 01/01/2010	Page: 1 OF 1	Prepared by: WH, CB, & MJ	Approved by: Commission – 10-23-17

1.0 PURPOSE:

To outline the policy and procedure for requesting utility service at locations currently served by Virginia Public Utilities.

2.0 REFERENCE:

City Code 3.04 subd. 1 (Application, Connection & Sale of Service)

3.0 POLICY:

An application for service and photo identification must be submitted in person before utility services will be placed in a customer’s name. If the customer is the owner of the property, proof of ownership/title must be presented prior to the name transfer occurring. If there is no proof of ownership, or if the customer is a tenant, a deposit according to the Customer Utility Billing Deposits Policy must be made prior to the name transfer occurring

Accounts will be closed for tenants upon their request; at which time final readings will be obtained and the account terminated. Responsibility for utilities will then transfer back to the property owner.

In the event of a transfer of ownership or transfer to a renter’s name, accounts will be closed for property owners upon their request. Final readings will be obtained and the account closed with the services remaining active.

The Department will not split bills on one meter or account.

A property owner may designate an agent to receive billings and provide for account maintenance. To designate an agent, the owner must deliver to VPU a written designation of the agent responsible for the payment of utility bills and account maintenance. The owner shall be responsible for notifying VPU of any change in the agent’s status.

VIRGINIA DEPARTMENT OF PUBLIC UTILITIES
POLICY

Subject: CUSTOMER UTILITY BILLING DEPOSITS			Index: CUSTOMER SERVICE	
			Number: 100.02	
Effective Date: 11/01/2017	Supersedes: 01/01/2010	Page: 1 OF 2	Prepared by: WH, CB, & MJ	Approved by: Commission – 10-23-17

1.0 PURPOSE:

To outline the policy and procedure for the necessity of customer deposits.

2.0 REFERENCE:

City Code 3.02 Fixing Rates and Charges

3.0 POLICY:

The deposit amount for each service address will be based on two times (2X) the highest month's bill from the previous year's consumption, or for a year when the premises was occupied.

- Deposits may be made in cash
- Deposits will remain on an account until the account is closed and the final billing paid in full. See Refund of Deposit below.
- An increase in the amount of the deposit can be requested if the current deposit on a customer's account does not meet VPU's two times (2X) the highest month's bill requirement.
- An increase in the deposit, up to three time (3X) the highest bill, can be requested in cases of repeated delinquency and/or where the outstanding balance on a customer's account is greater than the current deposit

Property Owners:

- Waiver of Deposit: The deposit requirement for utility service may be waived providing the service account is in the name of the property owner, transfer of title has occurred, and the property owner is a customer in good standing.

A property owner who has been granted a waiver of the required deposit may be required to post a deposit if their account has received excessive three or more Final Notices of Disconnection in the previous twelve (12) month period or if service has been disconnected due to non-payment.

Tenants:

- All tenants will be required to place a deposit on their account or provide a Guarantee in accordance with Utility policy on Guarantees as noted below.
- If a customer is purchasing the property under a Contract for Deed, the customer will be treated as a tenant as it relates to posting a deposit. Once the customer holds Title to the

property and it is recorded and the account is in good standing, the customer may request a refund of the posted deposit.

Foreclosed Properties

- The deposit requirement for utility service may be waived for properties in foreclosure or where a foreclosure is pending, where a licensed real estate professional, authorized by the foreclosing entity, requests the utilities be put in their name for the purpose of managing the property for the mortgage holder of the property. At the time of application, the real estate professional must provide the utility with the combination to the lock-box, emergency contact information, proof of management agreement, and the name of the mortgage holder at the time of application. Penalties for late payment will be waived if the property is VA, USDA, FNMA, FMAC, or GNMA. Final Notice of Disconnect fees will not be waived.
- Any real estate professional accessing this provision must be considered in good standing. A deposit will be required on all foreclosed property accounts when a real estate professional is determined to no longer be in good standing.

Guarantees of Accounts:

- A property owner who has been granted a waiver of deposit and is a customer in good standing may be allowed to guarantee payment on their tenant's account.
- A Guarantee of Payment form must be completed and submitted to VPU by the customer requesting the Guarantee. The Guarantor's signature must be notarized unless it is witnessed by VPU business office staff.
- A property owner can rescind their guarantee of payment by submitting a written notice to VPU. Such notice will be effective fifteen (15) days after the notice is received by VPU.
- Guarantees are not transferable from tenant to tenant - each tenant must provide a deposit or submit the guarantee from the property owner.
- Guarantees may be removed by VPU at any time upon their determination that the owner providing the guarantee is no longer a customer in good standing.

Interest on Deposits:

- All deposits shall earn interest at the rate established by the Minnesota Department of Commerce - rate is announced by December 15th of each year for all or part of the subsequent year.
- Interest will be credited to each account in December of each year.

Refund of Deposit:

- At the time an account is closed – termination – the deposit interest will be calculated and applied to the account as of the termination date.
- If there is a balance at the time of termination, the deposit will be applied to the customer's account and any remaining amount will be refunded once all obligations to the utility have been discharged.
- Deposits are non-transferable from one customer to another or from one account to another and are refundable only to the original applicant or applicant's designee providing proper identification.
- A Property Owner required to place a deposit on their account may submit a written request to VPU's Administrative Review Team to have the deposit refunded to them after a period of two years during which time the account has been kept current – paying billings by the due date each month.

VIRGINIA DEPARTMENT OF PUBLIC UTILITIES
POLICY

Subject: UTILITY BILLING			Index: CUSTOMER SERVICE	
			Number: 100.03	
Effective Date: 11/01/2017	Supersedes: 01/01/2010	Page: 1 OF 2	Prepared by: WH, CB, & MJ	Approved by: Commission – 10-23-17

1.0 PURPOSE:

To outline the policy and procedure for utility billing and consequences of late or nonpayment.

2.0 REFERENCE:

City Code 3.02 (Fixing Rates and Charges)
City Code 3.04 subd. 7 (Services and Charges)

3.0 POLICY:

Bills are payable on or before the due date indicated on each billing statement. A penalty will be charged per the current Utility Fee Schedule on all accounts not paid in full by the due date. The removal of this penalty may be allowed, upon request of the customer, if a record of prompt payment has been established for the previous twelve (12) months.

A Final notice of Disconnection will be charged per the current Utility Fee Schedule on all accounts not paid by 2:00 on the delinquent due date.

A Disconnect/Reconnect fee shall be charged, pursuant to the current Utility Fee Schedule, for all service calls to disconnect/reconnect or restore utility service as a result of the customer's failure to provide payment.

A Returned Check Fee shall be charged, pursuant to the current Utility Fee Schedule, for any checks returned to VPU for insufficient funds. The utility bill may be considered delinquent and subject to disconnection.

Utility Billing Payment Options:

1. Equal Payment Plan – VPU offers a program allowing equal payments each month to help customers equal out their monthly utility bills. In April of each year customers can sign up for an Equal Payment Plan (EPP) for the coming June through May period. The EPP will average the customer's bills based on prior usage for the previous twelve (12) month period – June through May along with an adjustment to cover inflation and seasonal factors. Residential and commercial property owners with service established for at least twelve (12) months and having accounts in good standing can apply.
2. Direct Deposit/Cash Transfer – a customer or his designated agent may request, on the form provided by VPU, direct automatic transfer of funds from a financial institution designated by the

customer to VPU for payment of utility service. The transfer shall be made on the due date of the regular billing of the account.

3. Payment Arrangements – It is the policy of VPU to assist customers by providing a means to avoid suspension of utility services for non-payment of utility billings in full by the due date. Upon request of the customer, a Payment Agreement can be set up outlining the dates and amounts to be paid by the customer in order to bring their account current. All Payment Agreements must be in writing and signed by the customer and be mutually agreeable to both parties.

VPU may deny a customer the right to enter into a Payment Agreement if the customer has failed to comply with previous Payment Agreements, has a history of payment problems with VPU, or who otherwise represents a significant risk of non-payment.

Billing Adjustments

In the event of inaccurate billing due to the failure of the owner's service piping, without knowledge or fault of the customer, an adjustment may be requested upon written application to VPU within a ninety (90) day period, and after complete and satisfactory repairs are completed by the owner. VPU may require the submittal of documentation of the satisfactory repair and may require inspection by VPU.

Adjustments to Water and Sewer billings due to leaky toilets, faucets left running, breaks/leaks in customer lines at the customer's side of the meter (unless a result of Meter Failure with VPU's meter), or other like items will not be adjusted. The Utility reserves the right to adjust water and sewer billings in extreme cases or in cases of inordinate financial burden.

Adjustment requests for Garbage charges (both City and County) must be addressed to the City of Virginia

If a customer disputes an adjustment, an appeal may be filed in accordance with VPU's appeal process.

The Utility has the right to make corrections to incorrect billings retroactively up to one (1) year.

Meter Failure

In the event of a meter failing to register properly, the customer shall be charged an estimate of the consumption from whatever may be considered the most reliable data or method available to VPU.

VIRGINIA DEPARTMENT OF PUBLIC UTILITIES
POLICY

Subject: APPEALS			Index: CUSTOMER SERVICE	
			Number: 100.04	
Effective Date: 11/01/2017	Supersedes: 01/01/2010	Page: 1 OF 1	Prepared by: WH, CB, & MJ	Approved by: Commission – 10-23-17

1.0 PURPOSE:

To explain a customer's right to appeal.

2.0 REFERENCE:

.

3.0 POLICY:

A customer has the right to submit an appeal to the VPU in order to resolve matters of utility billing and utility service. Customers may either submit a written appeal or a Policy Exemption Form to initiate the appeal process. All appeals will be processed by the Utility's Administrative Review Team (ART). Appeals of ART decisions may be made directly to the Commission.

VIRGINIA DEPARTMENT OF PUBLIC UTILITIES
POLICY

Subject: SHUT OFF FOR NON-PAYMENT OF UTILITY BILLINGS or REQUIRED UTILITY ACCOUNT DEPOSITS			Index: CUSTOMER SERVICE	
			Number: 100.05	
Effective Date: 01/01/2010	Supersedes: 10/24/88	Page: 1 OF 1	Prepared by: SL & WH	Approved by:

1.0 PURPOSE:

To define the circumstances where a customer's service could be shutoff for non-payment.

2.0 REFERENCE:

City Code 3.04 subd. 2 (Discontinuance of Service)

3.0 POLICY:

The Department may suspend service for non-payment of a utility billing and/or failure to meet deposit requirements.

If, prior to disconnection, a customer appeals a notice of involuntary disconnection, as provided by the Utilities' established appeal procedure, the Utility must not disconnect until the appeal is resolved.

The Department will comply with the State of Minnesota Cold Weather Rule currently in effect as it pertains to involuntary disconnection of service for non-payment of utility billings.

VIRGINIA DEPARTMENT OF PUBLIC UTILITIES
POLICY

Subject: RECONNECTION OF UTILITY SERVICE			Index: CUSTOMER SERVICE	
			Number: 100.06	
Effective Date: 01/01/2010	Supersedes: 10/24/88	Page: 1 OF 1	Prepared by: SL & WH	Approved by:

1.0 PURPOSE:

To outline the policy for reconnecting steam, water, gas, or electric services.

2.0 REFERENCE:

City Code 3.04 Subd. 6C (Unlawful Acts)

3.0 POLICY:

Reconnection of Utility Accounts that have been involuntarily turned off for non-payment is done during regular business office hours.

VIRGINIA DEPARTMENT OF PUBLIC UTILITIES
POLICY

Subject: TEMPORARY / SEASONAL DISCONNECTION OF UTILITY SERVICES			Index: CUSTOMER SERVICE	
			Number: 100.07	
Effective Date: 11/01/2017	Supersedes: 01/01/2010	Page: 1 OF 1	Prepared by: WH, CB, & MJ	Approved by: Commission – 10-23-17

1.0 PURPOSE:

To explain the policy and procedure for a customer to request temporary disconnection of utility services.

2.0 REFERENCE:

City Code 3.04 subd. 2 (Discontinuance of Service)

3.0 POLICY:

A customer may request VPU to turn off electric, water, or gas utility service for temporary/seasonal reasons and monthly service charges will not be billed.

However, a trip fee, pursuant to the current "Utility Fee Schedule", shall be charged for the temporary/seasonal disconnection and reconnection of electric, water, or gas utility services. The meters will be removed or sealed off. (See "Steam" below.)

If meters sealed off are tampered with and register additional consumption at the time the service(s) in question is turned back on, the customer shall be responsible for payment of all consumption and all previous unpaid monthly service charges.

All services not sealed off tight by a VPU employee shall have meters read and service charges billed.

Owners between tenants may request in writing that service be temporarily disconnected at a service address and the trip fee, pursuant to the current utility fee schedule, shall be charged. Meters will be removed or sealed off.

Because steam service lines must be kept heated to ensure the integrity of the District Steam Heating System, no customer will be allowed to turn off their steam service for seasonal disconnects with the intent to save on service charges. A customer may request VPU to turn the steam off tight for the season. A trip fee, pursuant to the current "Utility Fee Schedule", shall be charged for this service. The meters will be shut off tight, chained, and sealed off. No usage will be billed while the steam service is shut off tight.

VIRGINIA DEPARTMENT OF PUBLIC UTILITIES
POLICY

Subject: VOLUNTARY PERMANENT DISCONNECTION OF SERVICES			Index: CUSTOMER SERVICE	
			Number: 100.08	
Effective Date: 11/01/2017	Supersedes: 01/01/2010	Page: 1 OF 2	Prepared by: WH, CB, & MJ	Approved by: Commission – 10-23-17

1.0 PURPOSE:

To outline the Department’s policy on voluntary disconnection of utility services.

2.0 REFERENCE:

City Code 3.04 subd 2 (Discontinuance of Service)

3.0 POLICY:

The property owner of a building structure which will be demolished and no longer require utility services, is responsible for completing the Permanent Disconnection of Utility Services for Demolition of Structure form. Once received and all applicable fees paid, the Department will remove Department-owned meters (water, gas, & electric) and disconnect electric, steam, and gas services where applicable. The property owner is responsible for contacting and hiring contractor(s) to disconnect water services where applicable and in accordance with procedures set by the Department. If the property owner fails to disconnect services, or fails to pay for services disconnected by the Department, a special assessment will be placed against the property.

Payment of all fees for permanent disconnection of services in accordance with the current Utility Fee Schedule will be the responsibility of the Customer.

ELECTRIC

Electrical service will be disconnected at the pole by the Department of Public Utilities. The meter, meter base, and other equipment which may be owned by the Department shall remain the property of the Department.

WATER

Disconnection of water services shall be performed by a qualified contractor, bonded with the City of Virginia, at the property owner’s expense. Water services shall be disconnected at the corporation on the main and plugged, and the standpipe shall be removed. The Department may grant permission to disconnect a water service at the WSO if the corporation is located under a paved street or roadway. In this case, the standpipe shall remain in place and the property owner, his or her successors or assigns, shall accept responsibility for the remaining service stub. In the case of a joint service, the service to be terminated shall be disconnected at the point where it connects onto the common service. The disconnected service must be inspected by the Director of Distribution or his/her representative before backfilling. The water meter shall remain the property of the Department.

STEAM

See policy on Voluntary Permanent Disconnect of Steam Service.

GAS

Gas service shall be disconnected by the Department of Public Utilities at the main, or in the case of a joint service at the point where it connects to the common service. The disconnection shall be done at the property owner's expense. The gas meter and service regulator shall remain the property of the Department.

VIRGINIA DEPARTMENT OF PUBLIC UTILITIES
POLICY

Subject: REVENUE RECOVERY POLICY			Index: CUSTOMER SERVICE	
			Number: 100.09	
Effective Date: 11/01/2017	Supersedes: 01/01/2010	Page: 1 OF 1	Prepared by: WH, CB, & MJ	Approved by: Commission – 10-23-17

1.0 PURPOSE:

Virginia Public Utilities does not tolerate any intentional diversion or tampering of metering devices within its distribution system.

2.0 REFERENCE:

City Code 3.04 subd. 6 (Unlawful Acts)
City Code 3.99 (Violations a Misdemeanor)

3.0 POLICY:

It is the policy of the Utility to use every reasonable measure at its disposal to ensure revenue from all commodities and services supplied to customers is accounted for and properly billed and that the theft of commodities is kept at a minimum. All investigations and contacts with customers and/or property owners involved will be done in a professional manner.

VIRGINIA DEPARTMENT OF PUBLIC UTILITIES
POLICY

Subject: GENERAL METER POLICY			Index: CUSTOMER SERVICE	
			Number: 100.10	
Effective Date: 11/01/2017	Supersedes: 01/01/2010	Page: 1 OF 2	Prepared by: WH, CB, & MJ	Approved by: Commission – 10-23-17

1.0 PURPOSE:

To outline the Department’s policies in dealing with utility meters.

2.0 REFERENCE:

City Code 3.04 subd. 4 (Right of Entry)
City Code 3.04 subd. 5 (Meter Test)

3.0 POLICY:

All commodities furnished, or supplied by the Utility, will be metered or accounted for in such manner as to provide an accurate record of the commodity used.

RIGHT OF ENTRY

The Utility shall, as a condition of providing utility services, be allowed entry to all properties, upon proper notification to the customer and at reasonable hours, for the purpose of inspection, observation, testing, meter installation, maintenance, and reading. Failure of the customer to allow entry shall entitle the Utility to charge fees and enforce penalties or discontinue service until such time as entry is allowed.

METER ACCESSIBILITY

It shall be the responsibility of the customer to keep access to all meters free of rubbish, debris, bushes, shrubs, trees, snow and/or ice, building materials or any other items that prevent physical access to the meter and the area around all meters. Areas around all meters must be maintained in accordance with all local health codes. Failure to maintain meter accessibility is addressed through the procedure section on Policy Violation - Customer Notification.

Customers not maintaining accessibility to meters will receive a notification letter requesting the matter be corrected. See procedure for Policy Violation - Customer Notification.

METER DAMAGE

If a meter is damaged for any reason other than normal wear and tear, the customer may be required to pay the cost of repairing or replacing the meter as well as the estimated loss of revenue.

METER FAILURE

In the event of a meter failing to register properly, billing for the customer shall be calculated for the consumption from whatever may be considered the most reliable data or method available to the Utility. SEE ALSO: Utility Billing Section.

METER LOCATION – PROPERTY DAMAGE

The location of a meter(s) must be in a place satisfactory to the Utility before service will be supplied. Where meters are installed within a building, the Utility shall not be held responsible for damage from meter failure or water seepage from leaking meters, piping, or fittings.

METER READING

The Department reserves the right to estimate the meter readings if it is not possible for the Department to read meters at the time or if access to the meter is not made available. The Department is to be allowed access to read the meters, for billing purposes, a minimum of every three (3) months.

METER SERVICING

All meters (except steam) are owned and remain the property of the Utility and will not be removed unless service to the premises is discontinued or abandoned. The Utility shall maintain all meters necessary for measuring the commodity used by the customer. The Utility maintains the right from time to time to inspect, test, and maintain all meters that measure Utility-supplied commodities.

METER TAMPERING

SEE SECTION: Revenue Recovery

METER SEALING (SEALS)

All meters will be sealed, at the discretion of the VPU, following established procedures for the particular commodity. Once seals are applied, only Utility employees will be allowed to cut and remove a seal. Only seals authorized by the Utilities' Commission, or representative, will be used.

A seal that is found to be damaged, cut, or broken in any manner as to make the seal ineffective will be considered tampering. SEE SECTION – Revenue Recovery.

METER TESTING

The Utility will, upon written request from the customer, test any customer's meter(s). The customer shall be required to pay in advance the appropriate meter testing fee (see Utility Fee Schedule).

If the meter tests outside a two percent (2%) tolerance in registration under the conditions of normal operation, the meter testing fee will be refunded to the customer. The Utility will prepare a billing adjustment. SEE ALSO: Utility Billing.

All meters and/or metering equipment will be tested before installation. No meter and/or metering equipment will be placed into service or allowed to remain in service when known to have an error in registration in excess of two percent (2%) tolerance under normal operation.

VIRGINIA DEPARTMENT OF PUBLIC UTILITIES
POLICY

Subject: UTILITY LOCATION POLICY			Index: CUSTOMER SERVICE	
			Number: 100.11	
Effective Date: 01/01/2010	Supersedes: 10/03/88	Page: 1 OF 1	Prepared by: SL & WH	Approved by:

1.0 PURPOSE:

Gopher State One-Call is a dispatching center for location requests for the entire State of Minnesota and use of their services is mandated by State Law. It can be reached by dialing 8-1-1.

2.0 REFERENCE:

Minnesota Statute.

3.0 POLICY:

Any contractors or individuals who will be excavating in our service area must call Gopher State One-Call to request locations. Gopher State One-Call will then notify our Department. Direct requests for locations to this office will not be done. This is a State Law, therefore there will be no exceptions.

In addition, any location that our crews may require from other utilities must be routed through Gopher State One-Call. The Department will perform the location within 48 hours from receipt of the location request as required by law.

The Department will use the following colors for marking their facilities:

- Electric – Red
- Water – Blue
- Gas & Steam – Yellow
- Construction Site - White

VIRGINIA DEPARTMENT OF PUBLIC UTILITIES
POLICY

Subject: RESTORATION POLICY			Index: CUSTOMER SERVICE	
			Number: 100.12	
Effective Date: 01/01/2010	Supersedes: 7/23/01	Page: 1 OF 1	Prepared by: SL & WH	Approved by:

1.0 **PURPOSE:**

To outline the Department's policy in restoring Customer property after utility work is complete.

2.0 **REFERENCE:**

City Code 3.04 subd 8 (Customer's Responsibility)

3.0 **POLICY:**

To ensure equity and consistency of treatment to Utility customers, when it is necessary to disturb property, the Virginia Department of Public Utilities will follow uniform practices when restoring customer's property.

When the Department disturbs a customer's property in maintaining or replacing a service, the Department will only perform restoration work limited to backfilling of the trench and leveling it off one-time only.

The Department will not restore garage or house floors, fences, decks, shrubs, lawns, trees, concrete or bituminous sidewalks, patios or driveways, or any other man-made private property disturbed during the maintenance or replacement of customer service lines. Replacement of those items will be the responsibility of the customer at their expense whether the work is done by Utility crews or independent contractors.

VIRGINIA DEPARTMENT OF PUBLIC UTILITIES
POLICY

Subject: UTILITY OBSTRUCTION AGREEMENT			Index: CUSTOMER SERVICE	
			Number: 100.13	
Effective Date: 01/01/2010	Supersedes: 10/03/88	Page: 1 OF 1	Prepared by: SL & WH	Approved by:

1.0 PURPOSE:

To outline the Department's policy for Customers who build over or around utility service lines.

2.0 REFERENCE:

City Code 3.04 subd 8 (Customer's Responsibility)

City Code 3.04 subd 3 (Ownership)

3.0 POLICY:

Property owners who build over or around Utility services must sign an agreement acknowledging the presence of utility lines and agree to any and all costs involved to repairs of such utility service lines should there be a need. Any structure placed over or around a utility will be removed by the Department and it will be the owner's responsibility to replace.

VIRGINIA DEPARTMENT OF PUBLIC UTILITIES
POLICY

Subject: ELECTRIC SERVICE POLICY			Index: CUSTOMER SERVICE	
			Number: 100.20	
Effective Date: 11/01/2017	Supersedes: 01/01/2010	Page: 1 OF 2	Prepared by: WH & JJ	Approved by: Commission – 10-23-17

1.0 PURPOSE:

To outline the Department’s policy for installing and maintaining electrical service lines.

2.0 REFERENCE:

City Code 3.50 (Electric Service)

3.0 POLICY:

The Utility shall maintain and repair all electrical facilities up to the customer’s weatherhead connections or in the case of underground service, it shall be maintained up to the meter base connection. In Commercial installations the placement of the meter base will be at the Utility’s discretion.

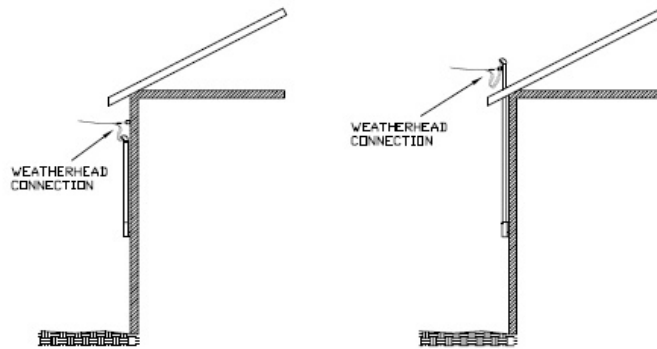

~ OVERHEAD SERVICE ~

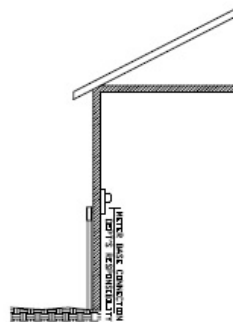

~ UNDERGROUND SERVICE ~

Notice to Customers Requesting a New Electrical Service Line:

The State of Minnesota requires that an inspection agreement be on file at the office of the Department of Public Utilities before a new electric service can be installed. The Department shall install the service after the estimate for installation is returned and the affidavit is on file. Any service calls ordered by the customer before this agreement is submitted shall be billed to the customer.

Notice to Customers Requesting a Reconnected Electric Service Line:

For the safety of our employees, the Virginia Department of Public Utilities may require the customer's main fuses or disconnect be de-energized by the customer before energizing any service. Once the wires are connected at the weatherhead, any wiring and energizing beyond the point of connection is the customer's responsibility. Should this reconnect occur anytime greater than six (6) months after disconnection, the Department requires an inspection by a licensed electrician before the service is energized.

Interference

Uses of electric services which cause disturbances on the electric distribution system and interference with service to other customers will not be allowed. Interference from the power line which cannot be traced shall be the customer's responsibility to filter out (if necessary).

Residential Electric Service

Electric service is available to a single family private residence at 60 cycle, single phase, at a nominal voltage of 120 volts or 120/240 volts, furnished through one meter for domestic purposes only, including lighting, small domestic appliances, refrigeration, cooking, domestic power using single phase motors 5.0 hp or less, water heating, and space heating.

Electric General Service (CI)

Demand meters to determine the 15-minute interval maximum average load will be installed at the discretion of the Department.

VIRGINIA DEPARTMENT OF PUBLIC UTILITIES
POLICY

Subject: TREE TRIMMING POLICY			Index: CUSTOMER SERVICE	
			Number: 100.21	
Effective Date: 01/01/2010	Supersedes: 03/07/88	Page: 1 OF 1	Prepared by: SL, WH & DR	Approved by:

1.0 PURPOSE:

To outline the Utility's policy on maintaining a safe clearance around power lines.

2.0 REFERENCE:

.

3.0 POLICY:

The Department of Public Utilities or a Representative thereof will perform all power line clearance tree trimming on public and private property within our service area. The property owner will be notified prior to the cutting. The necessity and extent of the trimming will be determined by the Department. Any power line interference is to be reported to the Department office.

VIRGINIA DEPARTMENT OF PUBLIC UTILITIES
POLICY

Subject: RAISING POWER LINES FOR HOUSE OR BUILDING MOVING			Index: CUSTOMER SERVICE	
			Number: 100.22	
Effective Date: 11/01/2017	Supersedes: 01/01/2010	Page: 1 OF 1	Prepared by: WH, CB, & MJ	Approved by: Commission – 10-23-17

1.0 PURPOSE:

To outline the Department’s policy on temporarily moving electrical lines.

2.0 REFERENCE:

City Code Section 3.50 (Electric Service)

3.0 POLICY:

Any party moving a building or equipment that would require the relocating, removal, or raising of any power line(s) shall be required to sign an agreement and meet all requirements below:

- The route must be approved by the Utilities Commission or designated representative.
- The building or equipment owner shall pay to the Department all costs incurred by the Department for labor expended and machines and equipment utilized in any way during the move, based upon the hours expended.
- The Line Crew will be present during the move. The building or equipment owner shall notify the Supervisor of the exact dates and hours for the move at least two business days in advance. The entire route of the move within the City of Virginia must be examined at least one (1) week prior to the move by the owner and the Supervisor. The owner must arrange for such an examination.
- The owner shall provide specific maximum dimensions of the building or equipment to be moved at least one (1) week prior to such move. The Supervisor, in his/her sole discretion shall determine what procedures are to be taken regarding utility poles and electrical distribution lines encountered during the move. An estimate will be prepared and forwarded to the party involved in the move. No work will be done until the signed estimate is returned.
- All bills incurred during the move shall be immediately due and payable upon preparation and shall bear the highest interest rate allowable.

VIRGINIA DEPARTMENT OF PUBLIC UTILITIES
POLICY

Subject: CONSTRUCTION & MAINTENANCE OF CITY STREETLIGHTS			Index: CUSTOMER SERVICE	
			Number: 100.23	
Effective Date: 01/01/2010	Supersedes: 03/07/88	Page: 1 OF 1	Prepared by: SL, WH & DR	Approved by:

1.0 PURPOSE:

To explain the relationship between various City entities in regards to streetlights.

2.0 REFERENCE:

3.0 POLICY:

The cost of maintaining existing lights shall be divided as follows:

- a) The Department will order and the City will pay for all repair parts require for maintaining existing lights
- b) The Department will provide all labor and equipment to keep the lights in proper working order

The cost and installation of new streetlights where no lights currently exist shall be at the expense of the City.

The ownership of the streetlighting system shall remain vested in the City.

The Department shall establish a streetlight placement, removal, and maintenance policy; and deviations shall be at the party requesting the deviation.

Streetlight work done solely at the request of or for the benefit of one of the parties shall not require a contribution from the other party. Examples of such cases may be but are not limited to: the changing of fixtures for economic reasons and the relocation of facilities for street widening.

Sound engineering and construction practices shall be used in order to maintain and install facilities with the most economical use of funds. This, however, shall not preclude the use of contract crews to perform work if the scheduling of the Department's crews is such that they cannot reasonably perform the work.

The City Police Department shall report the locations of inoperative lights.

Lighting surveys, maintenance, and construction shall be scheduled to fit the workload of the Department.

The Department shall review and approve all streetlighting construction projects.

Lamp replacement in traffic signals and other traffic signal work shall be handled by the Public Works Department.

VIRGINIA DEPARTMENT OF PUBLIC UTILITIES
POLICY

Subject: Distributed Energy Resource Interconnection Policy			Index: CUSTOMER SERVICE	
			Number: 100.24	
Effective Date: 5/28/19	Supersedes: 9/24/12	Page: 1 OF 1	Prepared by: WH & JJ	Approved by: Commission

4.0 PURPOSE:

To outline the Department’s policy regarding requirements which must be met before the Department will connect a Distributed Energy Resource to its distribution system.

5.0 REFERENCE:

City Code 3.50 (Electric Service)
Minnesota Statutes 216B.1611

6.0 POLICY:

Applicability

This policy applies to any resource having less than 10 MW capacity.

Interconnection Requirements and Processes

All interconnection requirements, terminology, processes, fees, contracts, rates, and timelines, will be consistent with State of Minnesota’s interconnection process as approved by the Minnesota Public Utilities Commission

VIRGINIA DEPARTMENT OF PUBLIC UTILITIES
POLICY

Subject: WATER SERVICE POLICY			Index: CUSTOMER SERVICE	
			Number: 100.40	
Effective Date: 11/01/2017	Supersedes: 01/01/2010	Page: 1 OF 2	Prepared by: WH, GF	Approved by: Commission – 10-23-17

1.0 PURPOSE:

To outline the Department’s policies in installing and maintaining water service.

2.0 REFERENCE:

City Code 3.04 subd. 8 (Customer’s Responsibility)
City Code 3.04 subd. 7 (Services and Charges a Lien)
City Code 3.30 (Water Service)

3.0 POLICY:

The water service line installation, service, repair, maintenance, and replacement is the responsibility of the property owner up to and including the service tap/corporation into the water main. This line must be and remain free of leaks, taps, or valves which could allow water to escape unmetered, and this line must be placed not less than seven feet below the surface so as to prevent rupture or stoppage by freezing, and laid in such a manner as to prevent rupture by settlement. The Utility shall furnish and maintain the metering device and its gaskets. Should the meter be damaged due to causes other than normal wear, the customer will be billed for its replacement.

Repair of leaks and freeze-ups from the main up to and including the WSO will be the responsibility of the Utility. Leaks and freeze-ups beyond the WSO are the responsibility of the customer. See “Water Service Leak Policy”. The Utility will not take responsibility for thawing of a frozen water line where an attempt to thaw from the WSO to the point of delivery was not made.

A fire protection system may be tapped into the incoming service line prior to the meter. However, permission, in writing, from the Commission is required prior to such an installation.

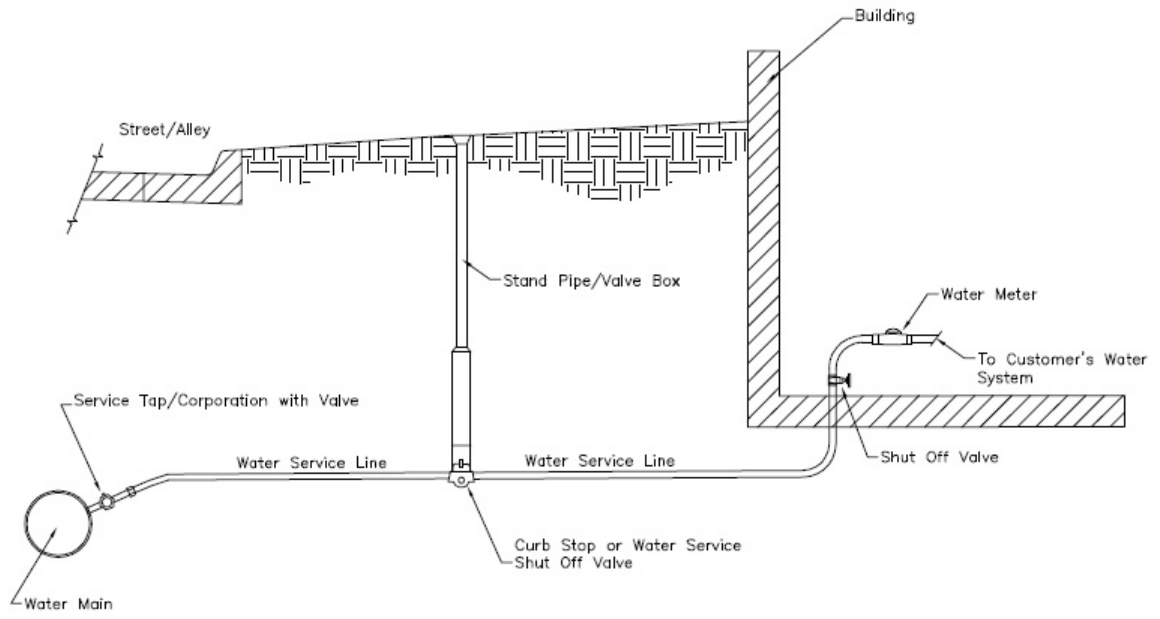

VIRGINIA DEPARTMENT OF PUBLIC UTILITIES
POLICY

Subject: WATER SHUT OFF (WSO) POLICY			Index: CUSTOMER SERVICE	
			Number: 100.41	
Effective Date: 11/01/2017	Supersedes: 01/01/2010	Page: 1 OF 1	Prepared by: WH, CB, & MJ	Approved by: Commission – 10-23-17

1.0 PURPOSE:

To clarify rights and responsibilities of customers, the Department, and the City as pertains to a water shut off (WSO) .

2.0 REFERENCE:

City Code 3.30 subd. 4 (Service Pipes)

3.0 POLICY:

As a service to our customers, during the service crew’s normal working hours the Department will make one (1) reasonable attempt to locate a customer’s WSO.

Should a home owner request the water be turned off at the WSO, the owner will be made aware of the following options:

1. The Department will attempt to turn off the water at the WSO contingent upon the following:
 - a) The customer is aware that any damage to the water service resulting from such an attempt by the Department is and shall remain the responsibility of the customer.
 - b) If the Department is unable to catch the valve because the standpipe is filled or partially filled with mud and/or debris, the Department will make one (1) reasonable attempt to clear out the standpipe. Should this attempt meet with failure, further efforts will be the responsibility of the home owner.

VIRGINIA DEPARTMENT OF PUBLIC UTILITIES
POLICY

Subject: WATER MAIN SHUT OFF POLICY			Index: CUSTOMER SERVICE	
			Number: 100.42	
Effective Date: 11/01/2017	Supersedes: 01/01/2010	Page: 1 OF 1	Prepared by: WH, CB, & MJ	Approved by: Commission – 10-23-17

1.0 PURPOSE:

To clarify the Department's policy on Customer requests for temporary water main shutoff.

2.0 REFERENCE:

City Code 3.30 subd. 4 (Service Pipes)

3.0 POLICY:

If a customer is making repairs on their plumbing and requests the Department of Public Utilities shut off their water at the WSO, the following will apply:

If the water cannot be shut off at the WSO the Department will shut the water main down to the area and the customer will be billed for shut off fees during normal work hours. Refer to Utility Fee Schedule for costs. This also requires a 48-hour notice for scheduling and public notification purposes when possible. Notification of such a shut-off will be the responsibility of the Utility

In cases where the customer has no WSO, he will be advised to install one on his service.

VIRGINIA DEPARTMENT OF PUBLIC UTILITIES
POLICY

Subject: BACKFLOW PREVENTION			Index: CUSTOMER SERVICE	
			Number: 100.43	
Effective Date: 01/01/2010	Supersedes: 03/07/88	Page: 1 OF 1	Prepared by: SL, WH, & GF	Approved by:

1.0 PURPOSE:

To outline the Department's policy on water backflow prevention.

2.0 REFERENCE:

City Code 3.30 subd 11 (Code Requirements)

3.0 POLICY:

The Department of Public Utilities may require that certain potable water connections be designed and installed to prevent contamination from chemicals, or backflow through the meters connected to the public water supply.

An approved backsiphon and backflow preventor, installed in an accessible location near the meter, may be required in order to get a water hookup and a water meter.

The installation of an approved device may be required at the time work is performed on an existing service.

These devices may be required on existing services at any time when the Department determines an extreme hazard exists.

VIRGINIA DEPARTMENT OF PUBLIC UTILITIES
POLICY

Subject: WATER LINE FREEZE PREVENTION (Formerly Water Bypass Policy)			Index: CUSTOMER SERVICE	
			Number: 100.44	
Effective Date: 11/01/2017	Supersedes: 01/01/2010	Page: 1 OF 1	Prepared by: WH, CB, & MJ	Approved by: Commission – 10-23-17

1.0 PURPOSE:

To out line the Department’s waterline freeze prevention policy.

2.0 REFERENCE:

3.0 POLICY:

In an effort to reduce freeze-ups and to reduce the amount of unaccounted for water the following applies

- At the Utility’s discretion, customers may be allowed to run an existing faucet or use by-pass equipment installed after the water meter to prevent freeze-up on their water service. Water meter bypasses are no longer allowed.
- Customers on the Freeze Prevention Program shall be allowed up to an average of 10 additional units of water (and sewer) per month or 40 aggregate units for the four months (December through March) at no charge to cover water used for freeze prevention
- Customers will be responsible for controlling the device used to prevent freeze-up on their service

This policy is not intended to permit future installations at depths less than seven feet, nor to preclude proper installations. The Department is not responsible for freeze-ups.

VIRGINIA DEPARTMENT OF PUBLIC UTILITIES
POLICY

Subject: HYDRANT USE POLICY			Index: CUSTOMER SERVICE	
			Number: 100.45	
Effective Date: 11/01/2017	Supersedes: 01/01/2010	Page: 1 OF 1	Prepared by: WH, CB, & MJ	Approved by: Commission – 10-23-17

1.0 PURPOSE:

To outline the Department’s policy on water hydrant usage by customers.

2.0 REFERENCE:

City Code 3.30 subd 8 (Opening Hydrants)

3.0 POLICY:

Permission shall be granted to use fire hydrants provided that the following provisions have been agreed to:

1. A Hydrant Use Permit must be completed before usage begins. The agreement will include the name of the requestor, the requestor’s company name, hydrant location, anticipated dates of use, and the signature of a Department supervisor.
2. User to assume all liabilities created by the use of the hydrant.
3. The amount of water used shall be metered and billed at the current rate. A user fee per the Utility Fee Schedule shall be paid at the time of application for each hydrant used. The user fee shall cover the Department’s expenses for hydrant setup, post-use inspection, and billing.
4. The user shall notify the Department as soon as possible after the hydrant is turned off.
5. All Hydrant meters are to be returned no later than October 31st.
6. The charge for pumping out the hydrant in the winter shall be per the Utility Fee Schedule for each time a hydrant is pumped.
7. The use of anti-freeze to prevent a hydrant from freezing is prohibited.

Hydrants privately owned are the responsibility of the owner. Maintenance, if requested, shall be charged at the current rate for labor and materials. Water shall not be used from these hydrants for any other use than for fires.

VIRGINIA DEPARTMENT OF PUBLIC UTILITIES
POLICY

Subject: WATER SERVICE LEAK POLICY			Index: CUSTOMER SERVICE	
			Number: 100.46	
Effective Date: 11/01/2017	Supersedes: 01/01/2010	Page: 1 OF 1	Prepared by: WH, GF	Approved by: Commission – 10-23-17

1.0 PURPOSE:

To outline Customer and Department requirements for water leaks.

2.0 REFERENCE:

City Code 3.04 subd 8 (Customer’s Responsibility)
City Code 3.30 subd 2 (Repair of Leaks)

3.0 POLICY:

As stated in Water Service Policy of the Department of Public Utilities Customer policies, “The water service line installation, service, repair, maintenance, and replacement is the responsibility of the property owner up to and including the service tap into the water main. This line must be and remain free of leaks, taps, or valves which could allow water to escape unmeasured.”

In the event a leak is discovered on the portion of a customer’s water service between the water shut off (WSO) and the point of delivery inside the building, the Department shall give written notification to the property owner informing them of the leak and allowing them seven (7) calendar days to repair said leak. Extenuating circumstances may be considered by the Department’s Water Supervisor.

The Department shall exercise its right to terminate service if:

- A. A leak is discovered which, if allowed to continue, may cause damage to public or private property; or
- B. A leak is not repaired within the specified time period. The costs incurred for the lost water based on an estimated flow and for terminating service shall be billed to the property owner.

VIRGINIA DEPARTMENT OF PUBLIC UTILITIES
POLICY

Subject: STEAM SERVICE POLICY			Index: CUSTOMER SERVICE	
			Number: 100.60	
Effective Date: 01/01/2010	Supersedes: 2/12/95	Page: 1 OF 1	Prepared by: SL, WH & GF	Approved by:

1.0 PURPOSE:

To outline the Department's policies for steam service installation and maintenance.

2.0 REFERENCE:

City Code 3.04 subd 8 (Customer Responsibility)

3.0 POLICY:

The Customer owns the service line from the main up to and including the main valve in the building. However, the Utility shall perform all maintenance to this service line and main valve.

- * Should a steam service line go through a building and serve more than one customer, the Utility is only responsible from the steam main to the main valve in the first building served by said service line. Any maintenance beyond this valve is the responsibility of the customer(s) served
- * Should a steam line go through a customer's property and connect to another steam main, the line in question shall be considered a steam main and will be maintained by the Utility.

The Utility shall also maintain the high pressure reducing valve and meter. All other maintenance and/or repair of steam systems such as replacement of low pressure or motorized valves shall be the responsibility of the property owner.

The Customer shall be responsible to divert roof drains, gutters, or any other high concentration of surface water away from steam service lines to help prevent premature deterioration of the steam piping system.

The main steam valve in the building shall be fully open or closed. If found to be partly opened or partly closed, the customer may be charged for a new valve should the Utility determine in needs to be replaced.

**VIRGINIA DEPARTMENT OF PUBLIC UTILITIES
POLICY**

Subject: STEAM SYSTEM REQUIREMENTS			Index: CUSTOMER SERVICE	
			Number: 100.61	
Effective Date: 01/01/2010	Supersedes: 03/07/88	Page: 1 OF 2	Prepared by: SL, WH & GF	Approved by:

1.0 PURPOSE:

To outline a Customer's responsibilities for steam system maintenance.

2.0 REFERENCE:

City Code 3.04 subd. 8 (Customer's Responsibility)

3.0 POLICY:

A customer's steam system must be and remain a closed system free of leaks, taps, or valves which could allow live steam or condensate to escape unmetered. All condensate, other than that which is discharged from a customer's service trap, must be metered.

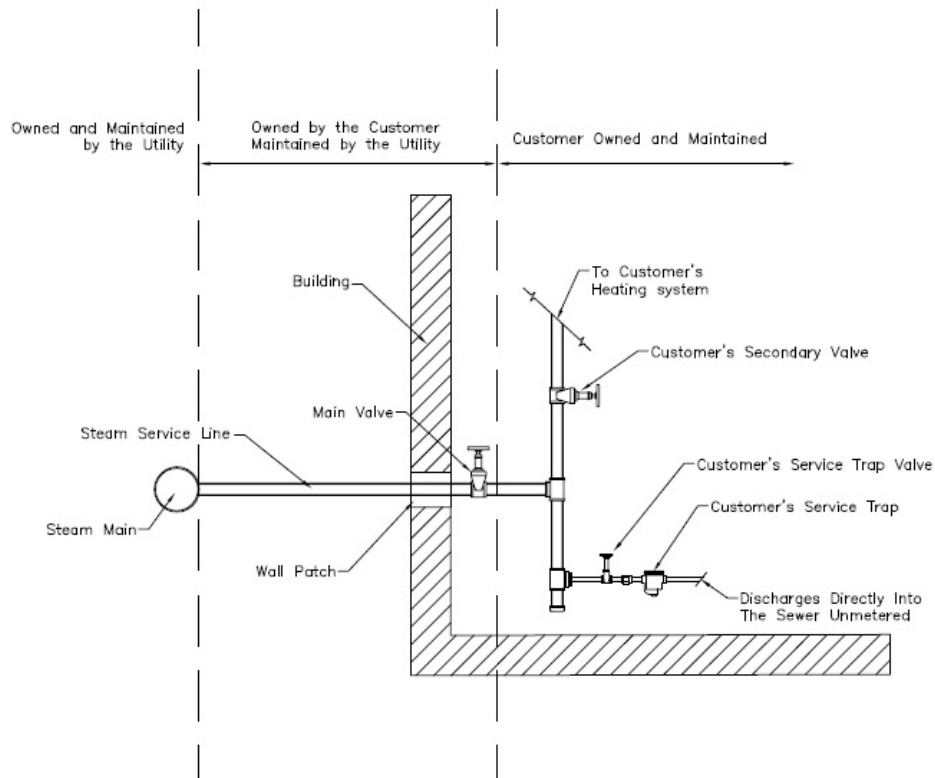

The main service pipe must, immediately upon entering the building, be tapped to the highest point of the customer's heating system which shall be arranged to carry all condensation in the same direction as the flow of the steam and to drain all condensation to a common point and into the trap or receiver. Where two or more drip pipes or returns are connected together, they must be trapped to form a water seal of sufficient depth to prevent steam from one interfering with the free discharge of water from the other.

All live steam lines, traps, valves, unions, meters, and return lines in buildings are to be maintained free of leaks and kept visible for inspection. No steam or condensate return lines are to be buried underground, in or under concrete, or covered by wall coverings, etc., unless access is maintained for visual inspection. Any leaks in the customer's system must be repaired promptly. The Department reserves the right to cut off the supply of steam with proper notice when such piping, fittings, radiators, and appliances are not maintained in good repair, or if any other violation of the steam metering regulations are detected.

All new installations shall be approved prior to connecting to the steam service by a representative of the Department.

No customer, plumber or contractor may alter, improve, or perform any maintenance on an existing condensate return system without obtaining prior approval from a Department representative.

All unions and plugs must be sealed at all times. If repairs are to be made and the seal broken, the Department must be notified immediately.

VIRGINIA DEPARTMENT OF PUBLIC UTILITIES
POLICY

Subject: STEAM SERVICE TRAPS			Index: CUSTOMER SERVICE	
			Number: 100.62	
Effective Date: 01/01/2010	Supersedes: 03/07/88	Page: 1 OF 1	Prepared by: SL, WH & GF	Approved by:

1.0 PURPOSE:

To outline the Department's policy on steam service traps.

2.0 REFERENCE:

City Code 3.04 subd. 8 (Customer's Responsibility)

3.0 POLICY:

The Department will allow a customer service trap after the main valve to discharge condensate from the incoming service line. This trap must drain by gravity by the shortest distance to the drain with no radiators or heat-capturing devices on this line.

Should the property owner request the relocation of an existing main steam service shutoff valve serving his/her property or should the installation of a customer service trap necessitate a relocation of said valve, the Department will perform the service. However, it shall be the property owner's responsibility to supply and reconnect all piping from said valve to the existing steam system within the building.

4.0 DEFINITIONS:

.

VIRGINIA DEPARTMENT OF PUBLIC UTILITIES
POLICY

Subject: STEAM METERS			Index: CUSTOMER SERVICE	
			Number: 100.63	
Effective Date: 01/01/2010	Supersedes: All previous	Page: 1 OF 1	Prepared by: SL, WH & GF	Approved by:

1.0 **PURPOSE:**

To outline the Department's policy on steam meter installation and maintenance.

2.0 **REFERENCE:**

City Code 3.04 subd. 8 (Customer's Responsibility)
City Code 3.04 subd. 5 (Meter Test)

3.0 **POLICY:**

The Department will service existing steam meters as needed, at Department expense. The meter must be at least 12" above the floor with the outlet pipe running as short a distance as possible to the drain.

The Department will not perform maintenance work on a meter that is not installed on a customer's service. The exception will be a meter that is scheduled for installation on a specific new service. Any work performed will be billed at the prevailing rate.

A new customer may purchase a new meter from the Department at the replacement cost, or a reconditioned used meter, if available, at cost of 20% of the cost of a new meter. A new customer who has a used meter to install must bring it to the Meter Department to be serviced. The customer will be charged at current rates for labor and materials.

It is a violation to allow live steam to blow through the meter and down the drain, or out the vent.

Meters are to be sealed. Any tampering with the meter is a violation and responsible parties will be prosecuted. See Revenue Recovery Policy.

In the event an accurate meter reading cannot be obtained for various reasons, the Department reserves the right to install a flow or turbine meter at the service entry point of a customer's heating system. Where a discrepancy between the reading on the flow meter and the readings on meters that are metering separate facilities in a multi-unit complex, the difference will be billed to the Owner or Lessee of said property.

The Department is responsible for installation, removal, and maintenance of the flow or turbine meter. The property owner will be responsible for damage occurring to the flow or turbine meter because of tampering, construction, re-plumbing, etc. and will be billed for replacement or repair costs.

VIRGINIA DEPARTMENT OF PUBLIC UTILITIES
POLICY

Subject: NEW STEAM SERVICE INSTALLATION POLICY			Index: CUSTOMER SERVICE	
			Number: 100.64	
Effective Date: 01/01/2010	Supersedes: 09/14/92	Page: 1 OF 2	Prepared by: SL, WH & GF	Approved by:

1.0 PURPOSE:

To outline the department's policy on steam service installation.

2.0 REFERENCE:

City Code 3.04 subd. 1 (Application)
City Code 3.04 subd. 8 (Customer's Responsibility)

3.0 POLICY:

The Virginia Department of Public Utilities will install a steam service line to a new or existing building, not presently served by steam, under the following conditions:

1. The Customer will make a written request for steam service to the Public Utilities Commission. This request for service should include the Customer's service requirements, anticipated load, and service entrance location.
2. The Department will install the steam service from the main into the building and install a main shutoff valve. It shall be the responsibility of the Customer or the Customer's contractor to install all piping, fittings, and equipment located downstream of the main valve. The maintenance of the steam service, from the main up to and including the main shutoff valve, is the responsibility of the Department.
3. The Customer owns the steam meter and is responsible for providing a meter of suitable capacity to meter all steam supplied through the new service. The Customer may purchase a steam meter from the Department or other sources.
4. In the event the steam service is to be installed into a building under construction, the Customer shall provide an opening through the basement or footing wall, or floor, large enough to allow for the steam pipe installation into the building. If the steam service is to be installed into an existing building, the Owner will provide for the necessary opening into the building.
5. The steam service will be installed by the Department or the Department's contractor with the Department computing the total installation cost. The Department, upon request by the Customer, will provide an itemized list of the service installation costs.
6. The installation cost for the steam service shall include all materials (pipe, fittings, valve(s), insulation, backfill material, concrete, and/or blacktop), labor, and equipment required to install said service.
7. There will be no costs billed to the Customer upon completion of the steam service. However, an agreement will be entered into between the Public Utilities Commission and the Customer stating:

for a period of five (5) years (60 months), the Department will accumulate the total cost of the Customer's steam consumption and deduct this amount from the original service installation cost. After the 5-year period, the remaining balance, if any, will be billed to the Customer as payment for the service. If the total cost for steam purchases exceeds the installation cost, there is no charge to the Customer for the service.

8. The 5-year period shall begin the day the interior steam system is energized, or ninety (90) days after the service line is installed, whichever comes first.
9. This policy applies only to service installations. Main extensions are not included in this policy.

VIRGINIA DEPARTMENT OF PUBLIC UTILITIES
POLICY

Subject: <u>VOLUNTARY PERMANENT DISCONNECTION OF STEAM SERVICE</u>			Index: CUSTOMER SERVICE	
			Number: 100.65	
Effective Date: 1/22/18	Supersedes: 11/01/2017	Page: 1 OF 2	Prepared by: WH, GF	Approved by: Commission – 1/22/18

1.0 **PURPOSE:**

To clearly state the Utility’s responsibilities as regards steam service line disconnections.

2.0 **REFERENCE:**

City Code 3.04 subd. 2 (Discontinuance of Service)

3.0 **POLICY:**

Property Owners involuntarily terminated from the steam system shall bear no cost. Upon completion of the involuntary termination the steam meter shall become the property of the Utility and the abandoned service line will become the entire responsibility of the property owner. The property owner of a building structure to be voluntarily disconnected from the district steam heat system is responsible for notifying the Virginia Department of Public Utilities of their intent to discontinue steam service to their property by completing the Request for Voluntary Permanent Disconnection of Steam Service form. Once received the Utility will notify the customer of the cost associated with the disconnection. Monthly service charges will cease upon payment of the disconnection costs.

All Virginia Department of Public Utilities costs associated with the voluntary disconnection of steam service lines are the responsibility of the property owner as follows:

Single Customer Service Line. All inactive, abandoned or non-revenue producing Single Customer Service Lines voluntarily abandoned shall be permanently disconnected at the main. The property owner shall be financially responsible for **prepayment** of 100% of the Utility’s termination costs. The Department will, at its discretion and as workload permits, perform the permanent disconnection at the main. Upon completion of the permanent disconnection the property owner will be responsible for the removal of the abandoned steam service line.

Joint Customer Service Line. All inactive, abandoned or non-revenue producing Joint Customer Service Lines voluntarily abandoned shall be permanently disconnected at the closest point still “in service” such as a “Tee” on the joint service line. The property owner first terminating at the “Tee” will be financially responsible for **prepayment** of a pro-rata share of the estimated Utility termination costs at the main. The Department will, at its discretion and as workload permits, perform the permanent disconnection at the Tee. Upon completed the property owner is responsible for the removal of the abandoned steam service line beyond the Tee.

The Department will be financially responsible for and, at its discretion and as workload permits, perform permanent disconnection at the main for any inactive, abandoned, or non-revenue producing steam lines still connected to the district system – i.e. those service lines abandoned prior to the 2003 revision of the Voluntary Permanent Disconnection of Steam Service Policy.

Voluntary Disconnect and Conversion after Enactment of this New Policy. If 80% of the customers downstream of an existing valve petition for voluntary steam service termination, the main line will be terminated with no charge for permanent disconnect. The 20% or fewer who will be *involuntarily* abandoned will be eligible for rebates, get two year notification and all served by the main will pay the current monthly service charge until the main is permanently disconnected from the active system. The current monthly service charge will remain in place until all customers on that main are permanently terminated and the line is de-energized.

The Utility may involuntarily terminate all customers downstream from an existing valve if 80% of the said customers once served by the steam system have voluntarily disconnected.

**VIRGINIA DEPARTMENT OF PUBLIC UTILITIES
POLICY**

Subject: GAS SERVICE POLICY			Index: CUSTOMER SERVICE		
			Number: 100.80		
Effective Date: 05/15/2013	Supersedes: 01/01/10	Page: 1 OF 2	Prepared by: WH, NG	Approved by: Commission - 3/25/13	

1.0 PURPOSE:
To outline the Department’s policies on gas service installation and maintenance.

2.0 REFERENCE:
City Code 3.04 subd 8 (Customer’s Responsibility)

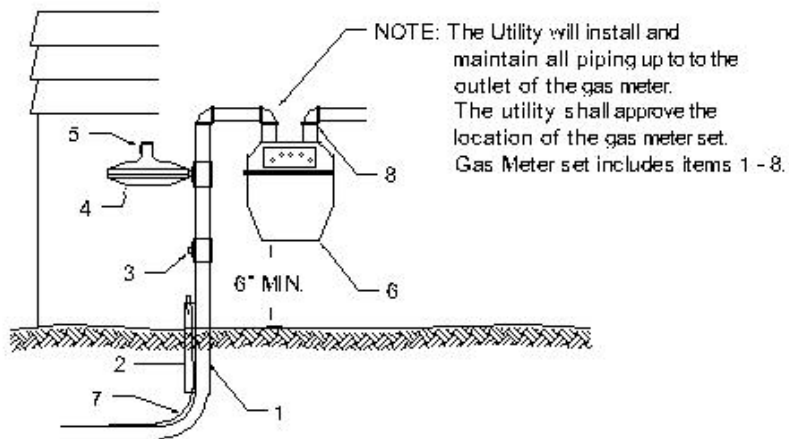

The Virginia Department of Public Utilities will be responsible for the operation, maintenance, and discontinuance of service from the meter to an including the connection at the main.

In areas where the gas distribution system is being rebuilt, gas services which are no longer being utilized to serve customers shall be abandoned in place and recorded on Department drawings.

- 1. ½" Steel Riser
- 2. ½" PVC Sleeve - 12" long
- 3. ½" Mueller Lock Cock (Riser valve)
- 4. Vent
- 5. Gas Regulator
- 6. Temperature Compensating Meter
- 7. Tracer Wire #12 Coated Copper
- 8. Meter Outlet (at Spud)

3.0 POLICY:

1. The Department of Public Utilities will install and maintain all piping and equipment up to the outlet of the gas meter.
2. The customer is responsible for ensuring the gas meter is protected from damage from ice, vehicles, etc. If the meter is damaged due to causes other than normal wear, the customer will be billed for repairs or replacement.
3. The Customer is responsible for installation and maintenance of all piping and equipment downstream of the meter outlet.
4. The Customer is responsible for ensuring the required maintenance of underground customer piping (buried underground downstream of the meter outlet; for example, garage services, pool heaters, or barbeque lines) is performed. This may include:
 - a. Locating and marking the pipe in advance of any construction activities
 - b. Monitoring the corrosion protection system, if the piping is subject to corrosion
 - c. Any other items required to maintain the integrity of the buried piping
 - d. In the interest of safety to all, notifying the Department of any new services to garages or outdoor appliances so that they can be mapped and included in the annual leak survey performed by the Utilities
5. In the event that the Department discovers a problem with the customer's piping which creates a safety issue, the Department may discontinue gas service to the premise until the safety hazard is corrected.
6. The Customer may contact the Department for assistance in ensuring the required maintenance of buried customer piping is performed. If the Department performs these services, the Customer may be charged. The Department may also direct the Customer to another source for these services.